

100/1000BASE-T DUAL TRANSFORMER MODULES

- ◆ Compliant with IEEE802.3 E and ANSI X3.263 standards
Including 350uH OCL with 8mA Bias.
- ◆ Dual Channel Interface For 100/1000 Mbps Ethernet Applications
- ◆ Comply With ROHS



ELECTRICAL SPECIFICATIONS@25°C (Operating Temperature :0°C to 70°C)

Part Number	Turns Ratio ±5%	Insertion Loss(dB max) 1-100MHz	Return Loss (dB min)				CMRR (dB min)			Cross Talk (dB min)			Hipot (vrms)
			1-30 MHz	30-60 MHz	60-80 MHz	80-100 MHz	1-30 MHz	30-60 MHz	60-100 MHz	1-30 MHz	30-60 MHz	60-100 MHz	
G48503MN	1:1	-1.0	-18	-14	-12	-10	-40	-35	-30	-45	-35	-30	1500
G48506MN	1:1	-1.0	-18	-14	-12	-10	-40	-35	-30	-45	-35	-30	1500

MECHANICAL

G48503MN, G48506MN

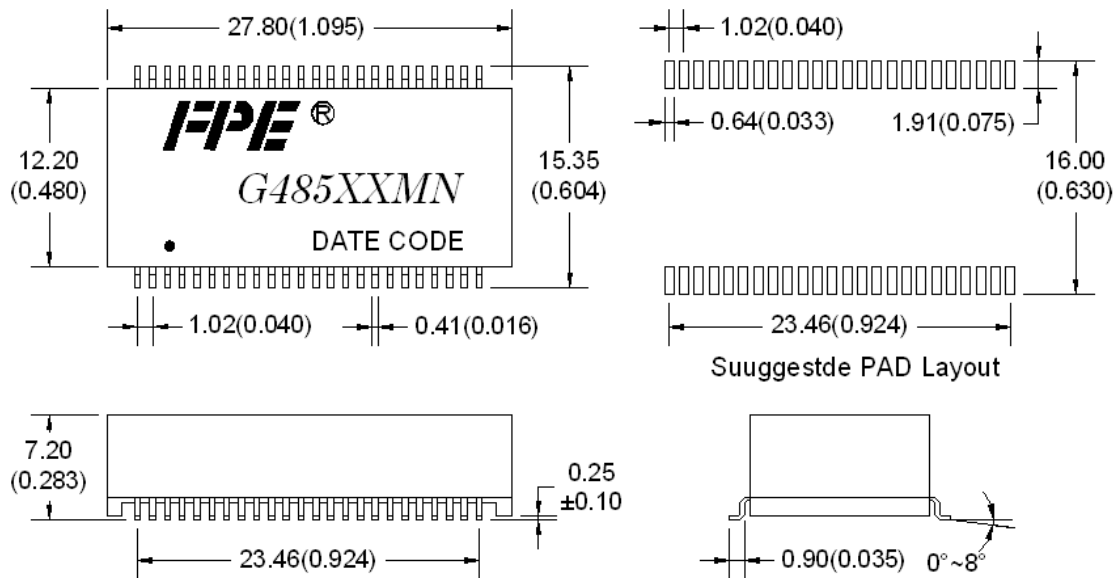

Units:mm(Inches) Tolerance:xx.x0±0.25(0.010) Weight.....2.80g TYP
 0.xx±0.05(0.002) Reel.....300Pcs

100/1000BASE-T DUAL TRANSFORMER MODULES

SCHEMATICS

G48503MN

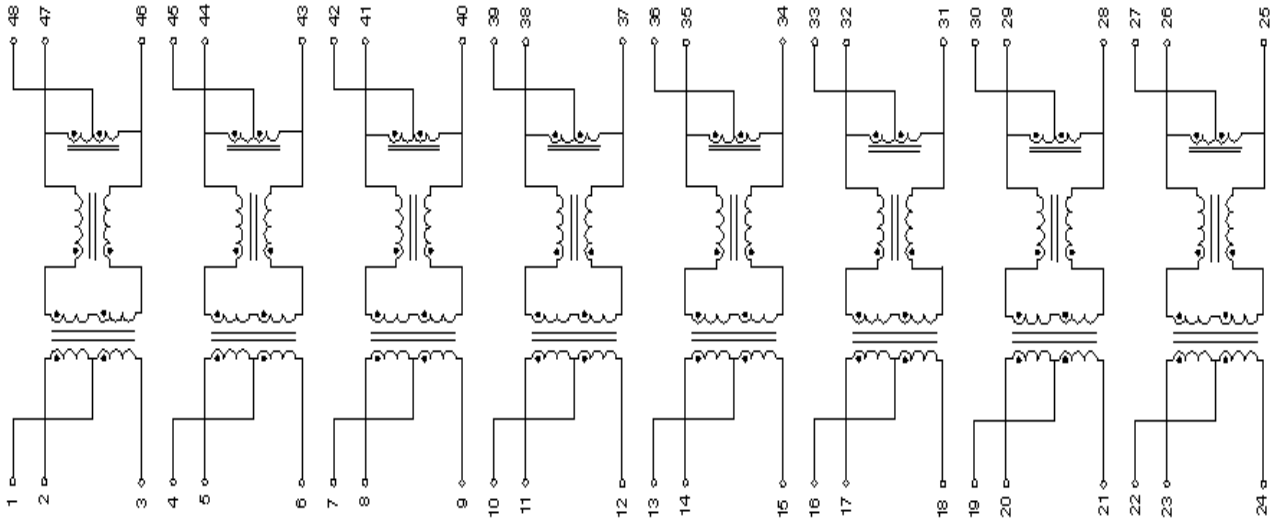

G48506MN

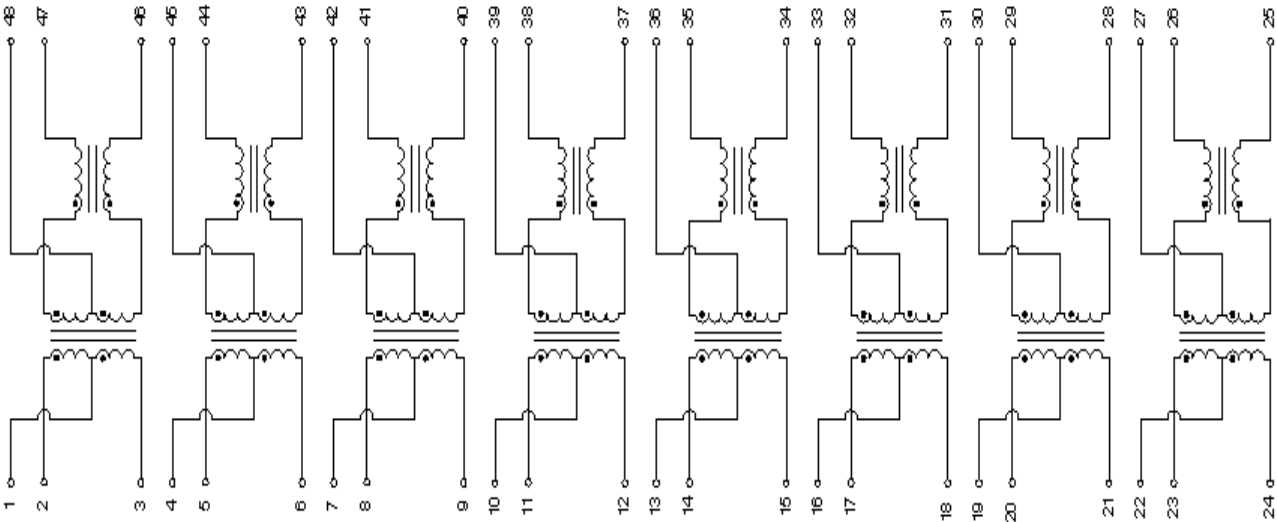

TaiWan Kinji Technology Limited

TEL:+886-3-3310896

FAX:+886-3-3310865

DongGuan Meixin Technology Co.,Ltd

TEL:+86-769-86761589

FAX:+ 86-769-86761549

ShangHai Qinshen Technology Co.,Ltd

TEL:+86-798-2620089

FAX:+ 86-798-2620186